

INNOVATIVE STEAM TECHNOLOGIES

OTSG STEAM GENERATOR TECHNOLOGY

GENERAL DESCRIPTION OF ONCE THROUGH STEAM GENERATOR (OTSG) TECHNOLOGY

1. INTRODUCTION

1.1 Background

This document details the unique benefits of Innovative Steam Technologies (IST) Once Through Steam Generators (OTSG). IST designs and manufactures Once Through heat recovery Steam Generators (OTSGs) for the industrial and power generation sectors. OTSGs are best suited, technically and economically, for the following applications:

- Combined cycle
- Cogeneration
- Gas turbine steam injection/cooling
- Off shore platforms
- Power barges
- Biomass Heat Recovery

Once Through Steam Generation is IST's solution to the limitations of traditional drum-type boilers. The continuous-flow steam generator of the OTSG system converts all feed water into high-purity, superheated steam, and through the simplicity and versatility of the design, achieves new levels of cost-effectiveness, performance and durability which are unmatched in the industry today.

This document addresses the following:

- Description and History of the OTSG
- Mechanical Design
- Environmental Controls – SCR and CO Catalyst Systems
- Water Chemistry Requirements
- Operation of the OSTG versus HRSG
- Control Requirements
- Maintenance Requirements
- Installation and Erection

This documents primary goal is to help the customer make an educated decision for their next heat recovery steam generator.

2. OTSG / HRSG DESCRIPTION

2.1 History of OTSG

The Once Through heat recovery technology was developed as a joint venture between Solar Turbines and the U.S. Navy. Their RACER (RAnkine Cycle Energy Recovery) program was based in San Diego, California, and was tasked with designing a light weight, fast cycling, high power and modular design to be used in the construction of the next generation of advanced naval ship. IST has further invested over 1,000,000 man hours and 8,000,000 operational hours in the continuing development of the basic OTSG technology and matured the technology into the robust and dynamic form it takes today. IST is the

only proven supplier of Once Through heat recovery steam generators. Competitors have tried, but failed to grasp the nuances of control and stability of OTSGs. After 20 years of refining our design, we are confident IST's OTSG is the only proven and reliable alternative to traditional drum-type HRSGs for gas turbines between 5 and 100 MW.

2.2 OTSG Design

The once-through steam generator (OTSG), in its simplest form, is a continuous tube heat exchanger in which preheating, evaporation, and superheating of the feed-water takes place consecutively, see Figure 1. Many tubes are mounted in parallel and are joined by headers thus providing a common inlet for feed-water and a common outlet for steam. Water is forced through the tubes by a boiler feed-water pump, entering the OTSG at the "cold" end. The water changes phase along the circuit and exits as superheated steam at the "hot" or bottom of the unit. Gas flow is in the opposite direction to that of the water flow (counter current flow).

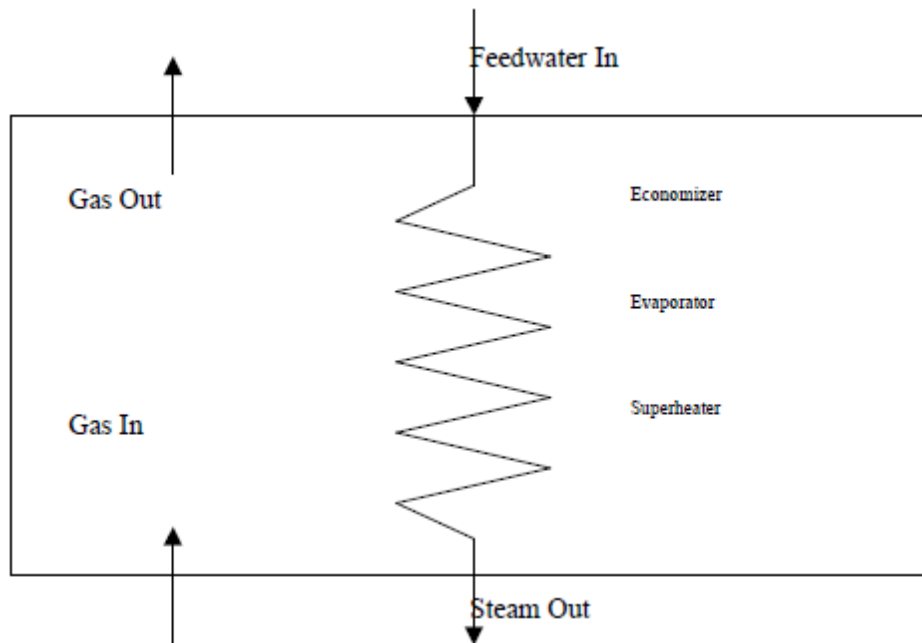

Figure 1: Once Through Steam Generator

Unlike conventional heat recovery steam generators (HRSGs), OTSGs do not have defined economizer, evaporator or superheater sections. The point at which the steam-water interface exists is free to move through the horizontal tube bank depending on the heat input and mass flow rate and pressure of the water. The single point of control for the

OTSG is the feed-water control valve; actuation depends on predefined operating conditions that are set through the distributed control system (DCS). The DCS is connected to a feed forward and feedback control loop, which monitor the transients in gas turbine load and outlet steam conditions, respectively. If a transient in gas turbine load is monitored, the feed forward control sets the feed-water flow to a predicted value based on the turbine exhaust temperature, producing steady state superheated steam conditions. Please refer to the Flow sheet (Figure 6) for illustration.

2.3 Evolution of the Superior HRSG

In the past decade Once Through Steam Generators (OTSGs) have evolved into a cost competitive and technologically advanced Heat Recovery Steam Generator (HRSG). This is the first new technology to be introduced into the heat recovery field since the wide scale introduction of combined cycles. Over 8 million operating hours have been accumulated on over 174 OTSG units now in service. However, many power plant developers and designers are not aware of the OTSG's superior technology and the many cost, operating and performance advantages that may be obtained when compared with drum boilers (Please note that IST has several case studies that can help you better understand these advantages).

2.4 Elimination of the Steam Drum and Blowdown System

Drum-type HRSGs have many components such as drums, downcomers, separate economizers, generating tubes, separate superheaters, circulation systems and blowdown systems that are unnecessary ancillary components not essential to produce steam efficiently. Water tube drum units were developed to prevent scaling, corrosion and allow control of the steam generating process. With modern materials, control systems, design technology, and water treatment IST has been able to eliminate these costly and slow responding systems necessary in traditional boiler design while providing the ideal platform for the modern combined cycle plant. Also unlike conventional HRSGs (Figure 2.), OTSGs do not have steam drums, mud drums or blowdown systems. Water volume is typically one-eighth to one-tenth that of a conventional drum-type HRSG. The absence of a blowdown system limits the steam generators thermal losses and lowers the makeup requirements to less than 0.1 percent of the total cycle flow rate, thereby permitting a smaller makeup treatment plant.

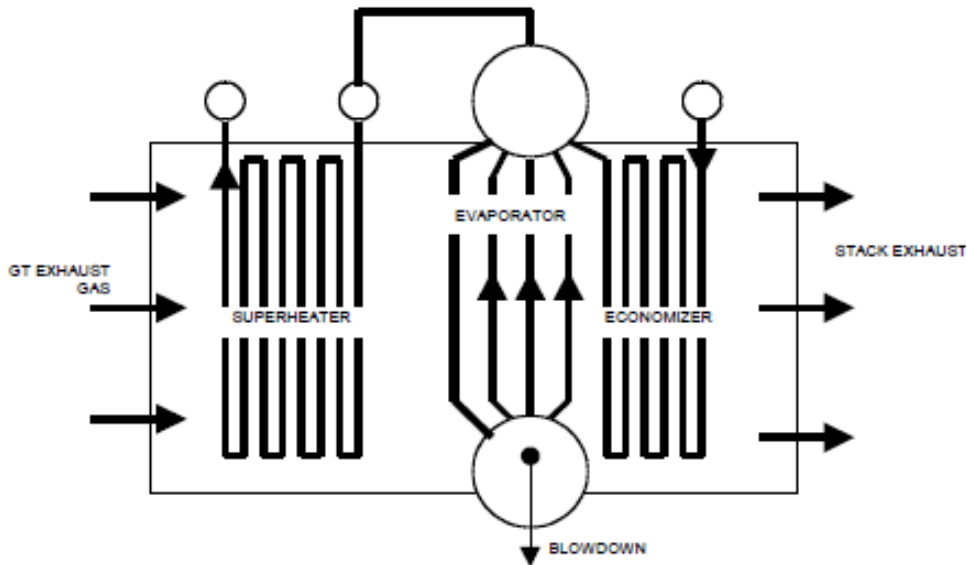

Figure 2: Drum-Type HRSG

2.5 Straight Forward Water Treatment

Increasingly water treatment is being required for all HRSGs. Good water treatment extends the life of the pressure tubes, monitoring instruments and the associated steam plant. Likewise, water treatment is important to the effectiveness of OTSG systems. Water quality in the OTSG is maintained using conventional deionization and polishing exchange systems, which eliminate deposition into the tube bundle and carryover to the steam turbine. Deionized water treatment systems and condensate polishers are not unique to OTSGs; they are being used with increased frequency on traditional drum-type HRSGs and are favored for any installation where life-cycle costs, high reliability, low and/or high purity steam is desired.

2.6 Very Small Footprint

OTSG technology is ideally suited for locations where space is restricted (power barge, urban distributed power, Brownfield). When configured for both combined cycle and cogeneration operations we typically arrange the system with vertical gas flow and horizontal tube systems. The horizontal tube configuration results in a smaller footprint, pushing the units vertically rather than horizontally. The addition of extra equipment i.e. an SCR or CO catalyst system does not add to the HRSG footprint because it only requires the addition of extra modules, only increasing the boiler height (See Figure 3).

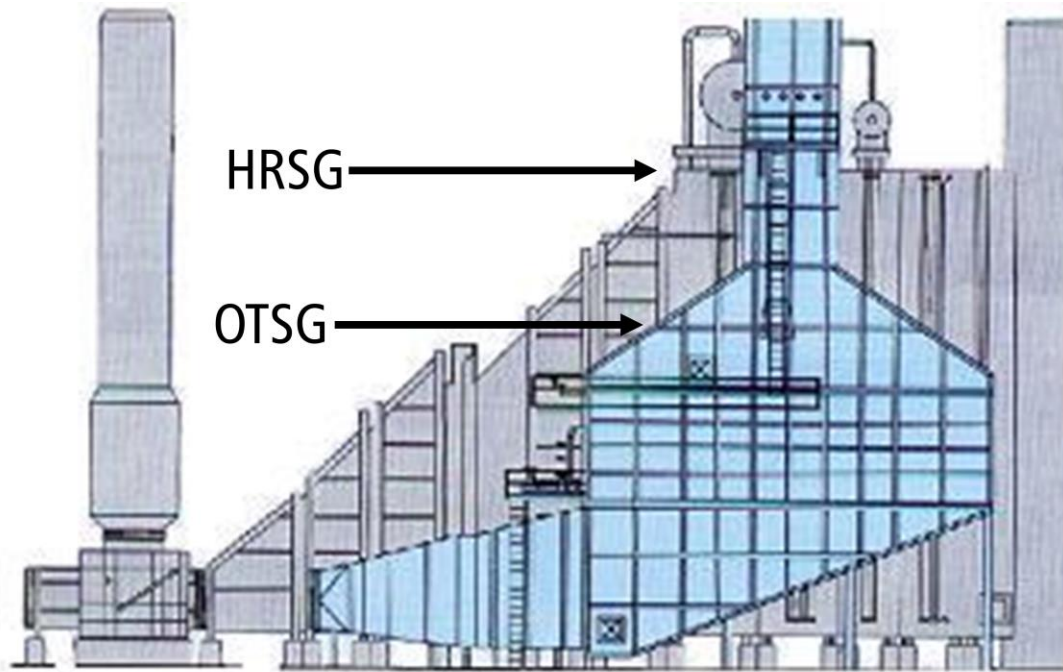

Figure 3: Comparison between conventional HRSG and the OTSG (LM6000 installation)

2.7 Unique Dry Run Capability

Conventional HRSGs use carbon steel as the tube material. Carbon steel loses strength at elevated temperatures, thus, making a bypass stack and diverter valves necessary to prevent the hot exhaust from damaging the tubes during dry running conditions. The OTSG uses high-nickel Incoloy 800 and 825 alloy tube material, which maintains a substantial fraction of its strength and corrosion resistance at high temperatures. This use of advanced materials, permits full dry running without the need for a bypass stack or diverter valves. In many jurisdictions of the world this capability simplifies the permitting process because only one stack requires a permit. Further, Incoloy tube material also limits the OTSG's oxygen sensitivity, avoiding the need for active chemical water treatment.

2.8 Small, Powerful and Light Weight Systems

The elimination of the bypass stack and diverter valve, together with the system's modular design, allows the design of the OTSG to be up to 60 percent smaller, lighter and more compact than a comparable HRSG. This unique and efficient design makes for a very small and light weight package which makes the OTSG suitable for projects that have size, weight or shipping restrictions. Additionally, this weight and size advantage is very

desirable for supply of to remote location of the world.

2.9 Compact Pressure Module

Figure 4 shows a typical OTSG pressure module and its steam/water flow path. Feed water is metered into the first rows of tubes on the OTSG's exhaust gas outlet end. Water and steam are directed by U-bends at each row to the hot inlet gas in a counter flow path until it reaches the desired superheat temperature and is collected in a header and directed to the steam turbine. Water is heated, evaporated and superheated in one continuous flow path within each of the many parallel circuits. Any orientation can be configured, since gravity forces are not used in the design. Water flow can be down with exhaust gases vertically upwards, or it can be horizontal gas flow with vertical. All of these configurations have been extensively tested and installed. This design flexibility, allows us to design a very compact and efficient steam generator.

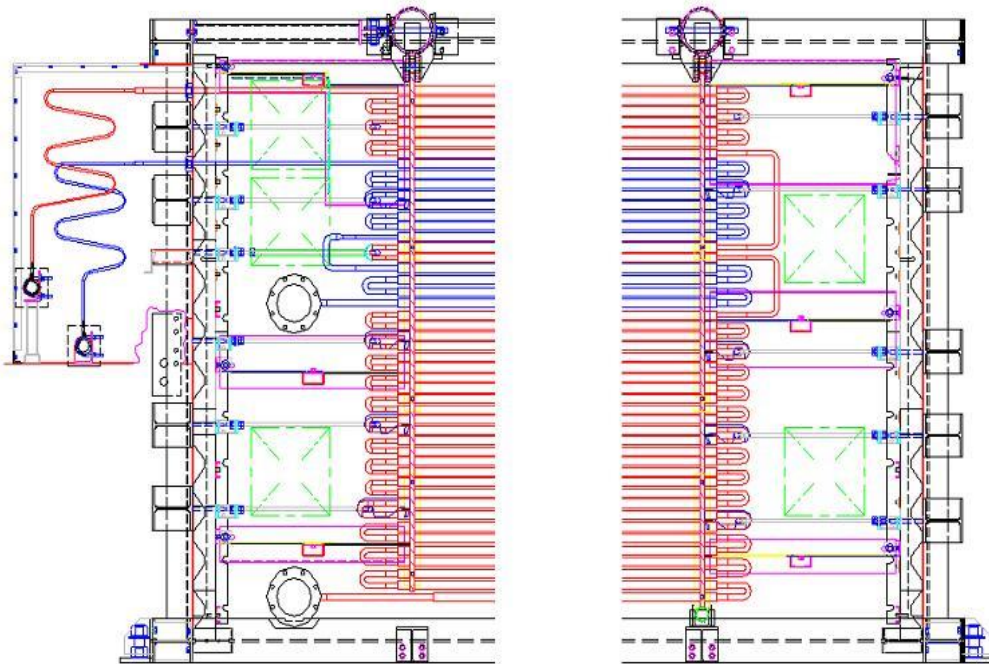

Figure 4: Typical OTSG pressure part module

2.10 Modular Design and Fabrication

All of our OTSG systems are fully modular comprising five major components: 1) the inlet module, 2) plenum module, 3) the pressure module (OTSG), 3b) the environmental controls module (optional), 4) the hood module, 5) the stack module. Each of the modules are



factory designed and built to exacting standards. The pressure module (OTSG) is usually in a single module with the entire ASME Section I boiler proper components factory welded and code inspected before leaving our state of the art fabrication plant. Factory construction of the pressure module leads to high quality control and 100% inspection of all pressure welds by means of ultrasonic testing. A single pressure module (OTSG) can be shipped in sizes up to about 30,000 square meters (300,000 square feet) to any location in the world. The modular approach minimizes erection and installation cost and time. This reduces the project's gestation period and causes the combined cycles to become increasingly more attractive to developers and financiers. The addition of an SCR or CO catalyst system does not add to the boiler footprint because it only requires the addition of extra modules, only increasing the boiler height (See Figure 5).

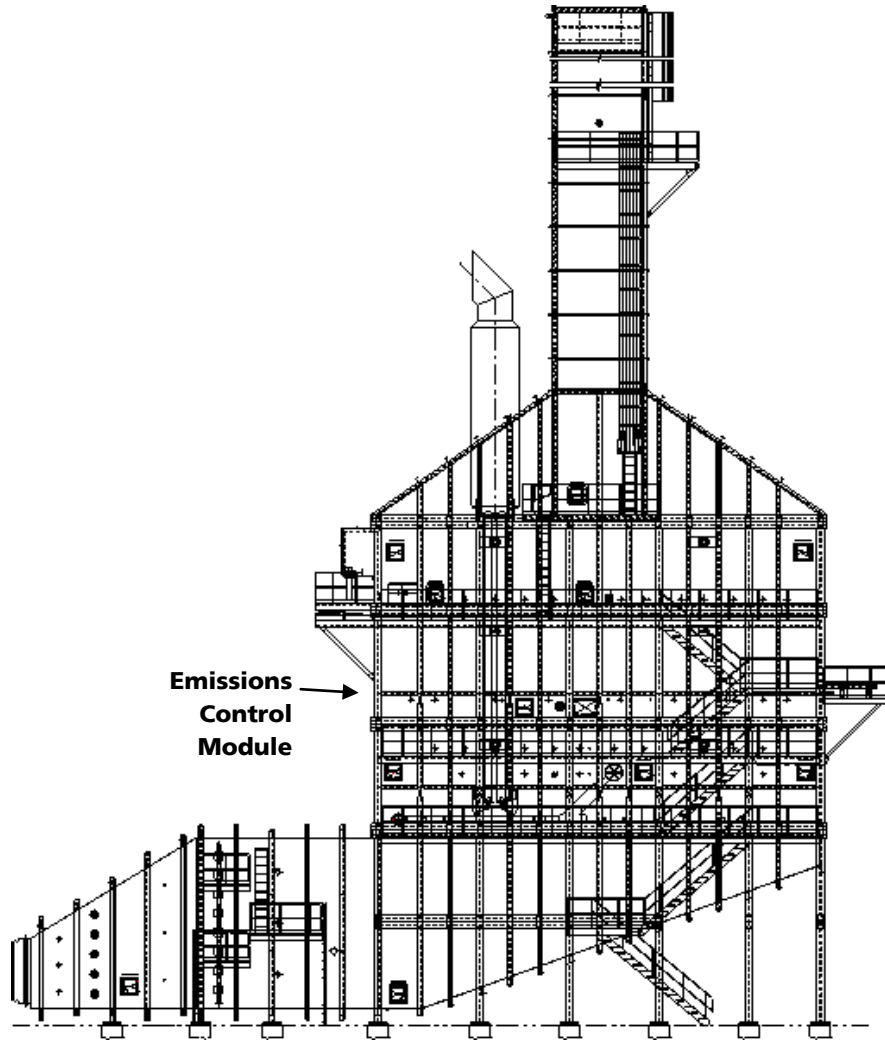

Figure 5: Emissions control module location

Table 1: Overview of OTSG modules

Module	Purpose	Standard	Option
1) Inlet Duct Module	GT exhaust duct to the OTSG	X	
2) Plenum Module	Support Base for the OTSG	X	
3) OTSG Module	Steam Generator Module	X	
4) Environmental Module	SCR and CO abatement		X
5) Hood Module	Cap module for the OTSG	X	
6) Stack Module	Exhaust stack	X	

3. MECHANICAL DESIGN

3.1 Design Features

OTSG uses specially developed and fabricated finned tubes matched to the operating requirements of the customer. Most of the 105 OTSG units in operation to date have a requirement for dry run operation at full gas turbine power. As discussed, the tubes are made of high nickel alloy and are capable of exposure to high temperatures as per Section I of the ASME Boiler Code. Dry operation with most current gas turbines allows the use of carbon steel fins, which are currently installed on many OTSGs for the most cost-effective heat transfer surfaces; stainless steel fins are employed when the ambient conditions are severe. The high nickel stainless steel tubes permits the use of passive water treatment (PWT) with the OTSG. The proprietary finned tubing manufacturing process allows many different combinations of fin material to be bonded to the high nickel seamless/welded tubes. This bonding process allows operation of the tubes to temperatures over 1500°F if stainless steel fins are used. For most applications carbon steel fins are optimum but stainless steel fins have been operated to high temperatures or installed in cold economizer rows without feedheating to improve performance while minimizing corrosion caused by water condensation.

3.2 Reduction of Stresses Through Unique Flexible Design

HRSBs are susceptible to the cold end problems in the preheater rows of the boilers. These problems include corrosion or stress corrosion cracking of the carbon steel or stainless steel heat exchanger tubes and corrosion of the carbon steel fins due to operations below the acid dew point. In order to avoid these types of cold end problems, HRSBs are designed to accommodate slightly higher stack temperatures and higher feedwater temperatures, which, in turn, can reduce the overall plant efficiency. OTSG systems employ alloy 825 and stainless steel fins in the inlet rows (economizer) of all the pressure levels and a preheater is not required. These materials minimize the effects of corrosion; therefore the OTSG systems accommodate lower feedwater (as low as 60°F) and therefore lower stack

temperatures. The majority of our installed OTSG units accommodate exhaust gas that flows vertically upward and the water flow enters at the top and flows downward through the serpentine tube bundle to exit at the bottom as superheated steam. Every few feet flexible tube sheets support the bundle. The tube sheets are hung from the top by cross beams mounted on side pads that compensate the structure for differential thermal growth (Figure 6). A thermally matched spreader system adjusts the support beam position to allow compensation for thermal expansion. The tubes are free to slide within the tube sheets, and the tube sheets can flex with the entire bundle. This construction allows a high degree of thermal flexibility and is needed for dry operating capabilities and cyclic duty applications. Multiple pressure units are configured by the use of longer u-bends or jumper tubes that allow different pressure level sections of the OTSG to be located in the optimum gas temperature zone for best performance. Figure 6 illustrates a typical arrangement of u-bends and jumper tubes. Since separate drums and the large amount of interconnecting piping are not needed for multiple pressure sections, the OTSG is both simpler to build maintain and control. Additionally, the OTSG becomes more cost effective as the number of pressure levels increase and the size of the steam generator grows.

4. SCR AND CO CATALYST SYSTEMS

As environmental regulations dictate equipment selection for power plants, SCR and CO catalysts are being integrated into HRSGs. The OTSG can be easily outfitted with an SCR or CO catalyst by simply adding an extra module space for the catalyst, ammonia injection grid or mixing space (See figure 5). Roughly 10% of IST's boilers sold to date have required SCR installations. Due to the inherent design flexibility of the OTSG, we can design a system where the catalysts have a defined temperature zone where they operate at peak efficiency. Because the OTSG has no fixed sections, the tube bundle can be split at any location and the SCR inserted. This allows the SCR to see the optimal temperature much more easily in an OTSG.

5. WATER CHEMISTRY REQUIREMENTS

Consistent management of water and steam side chemistry is essential for long term reliability and durability of the HRSG. High pressure boilers are very unforgiving of even isolated major chemistry excursions. The thin wall tubes used in both HRSGs and OTSGs leave no practical corrosion margin for even occasional chemistry excursions. Post construction chemical cleaning of water side components and steam purge of steam pipes is extremely important to long term durability of HRSGs. Many HRSGs, which were not thoroughly cleaned, have suffered corrosion from failure to completely drain while shutdown due to clogging of maintenance drains. This problem is not experienced with OTSGs systems. As explained above, the OTSG has polished feed water entering the unit and in turn clean steam leaving the unit. The OTSG does not contain or add any impurities to the system and the unit arrives with 100% of the pressure parts completed and sealed in a clean state. In addition, any water that is contained within the tube bundle during a

shutdown scenario will completely boil dry due to the residual heat contained within the fully insulated unit. This feature will increase the plant's operability and reduce the maintenance requirements that would have otherwise been encountered if a HRSGs were used. The high nickel stainless steel tubing is of small diameter and thin walls. Water solids are removed externally and not in the steam generator and no chemicals are needed for the OTSG. Oxygen removal is also unnecessary and typical control of feed water chemistry and drum chemistry is not used in operating OTSGs. Only a simple conductivity transducer is used to monitor the OTSG's feed water total dissolved solids (TDS) levels of less than 50ppb or less than a cation conductivity of 0.25 micromhos/ cm. In a power plant application (no steam loss to process) a 0.1% or less makeup is commonly experienced (no blowdown required as with drum –type HRSGs) and exchange D.I. beds for make-up and full flow polishing is often the most cost effective solution. For cogeneration where makeup can be higher, some systems use reverse osmosis and exchange beds or regenerative D.I. systems. HRSGs traditionally have make up rates of 2.5% or higher in combined cycle applications. The 2.5% percent makeup is due to blowdown and steam losses through the system. The blowdown must be disposed of, and in some cases blowdown treatment is a requirement. Therefore, additional disposal equipment would be required, and the plant would have a thermal loss due to the blowdown.

5.2 OTSG Do Not Require Deaerators

Traditional HRSG systems require elevated thermal deaerators to reduce the dissolved oxygen in the water/steam. This is a requirement because of the carbon steel tubes and drums in the unit. The alloy 800 and alloy 825 tube material commonly used in OTSG systems are not oxygen sensitive, therefore the OTSG does not require deaeration to the same extent as the HRSG steam plants. Often there is carbon steel piping within the steam plants of combined cycles featuring OTSGs as the heat recovery boiler. Therefore, it is advisable that deaeration be used, and a vacuum deaerator may be the most practical alternative. A vacuum deaerator's physical size is smaller and the cost is often less. The vacuum deaerator also uses less steam than a tradition pressurized deaerator which could otherwise be contributed to the plant balance and improve the cycle efficiency. Vacuum deaerators cause lower feed water temperatures, however low feed water and stack temperatures do not promote corrosion problems for OTSGs in the cold economizer end.

6. OPERATION OF THE OTSG

6.1 Quick Startup and Fast Cycling Characteristics

The OTSG does not require steam or water drums nor does it require a blow-down system. Consequently all feed water entering the OTSG is converted to steam and a nominal amount of make up water is required. During start-up, steam production begins shortly after the admission of feed-water into the OTSG. Since steam production starts as soon as the temperature of the exhaust gas (exiting the OTSG) has reached the minimum required value, the thermal shock to the system is diminished and the life of the OTSG will be maximized.

6.2 Control Method for Steam Generation

Due to the advanced design of the OTSG, control of the unit is greatly simplified. As water is first admitted to the OTSG, the steam being produced will be very close to the temperature of the exhaust gas at the inlet to the OTSG. Steam temperature control can begin when the steam production has reached unfired full load unless a downstream attemperator is used. At this point, we then control the steam temperature by varying the feed water flow rate into the OTSG pressure module which then controls the steam temperature. Increasing feed water flow will decrease outlet temperature and decreasing the flow will increase the temperature. The flow rate of the feed water is controlled by means of an actuated water valve driven by your control system.

6.3 Startup Considerations

During the start-up period, the steam exiting the OTSG may be at a temperature higher than required by the steam process (depending on steam process and gas turbine design). Consequently, the steam plant must have a means of regulating the temperature prior to admission to the steam processes steam piping system. There are constraints on the ramp rates for the start of steam production on the OTSG's. In addition, there are constraints on the steam output pressure transients. In particular, rapid pressure transients must be avoided. Rapid pressure reductions can cause the water in the OTSG tubes to swell in sections where the water has not been fully evaporated. This may result in water being swept along into downstream tubing in the higher temperature zones creating a risk of tube failure.

6.4 Ramp up Rates are Faster than Other HRSG

The ramp rates for OTSG systems are considerably faster than drum-type HRSG systems, typically in the order of magnitude of 1/3 the time for a cold start. The OTSG contains significantly less water than a drum type unit and in fact the OTSG is started dry, therefore the unit does not have to wait until the large volumes of water contained within drum units heats and begins to evaporate. This causes the OTSG to be ideally suited for combined cycle applications where cycling or daily start-up and shutdowns are required. The cyclic load does not mechanically effect the OTSG since all the tubes and headers are relatively thin walled which means that the material is geometrically stronger than HRSGs under these loading scenarios. Figure 6 contains a typical start-up curve for a dual pressure OTSG system coupled to a 40MW LM6000 gas turbine.

OTSG Start-Up Curve

(Start Permissive approx 12 min from GT ignition without SCR/CO)

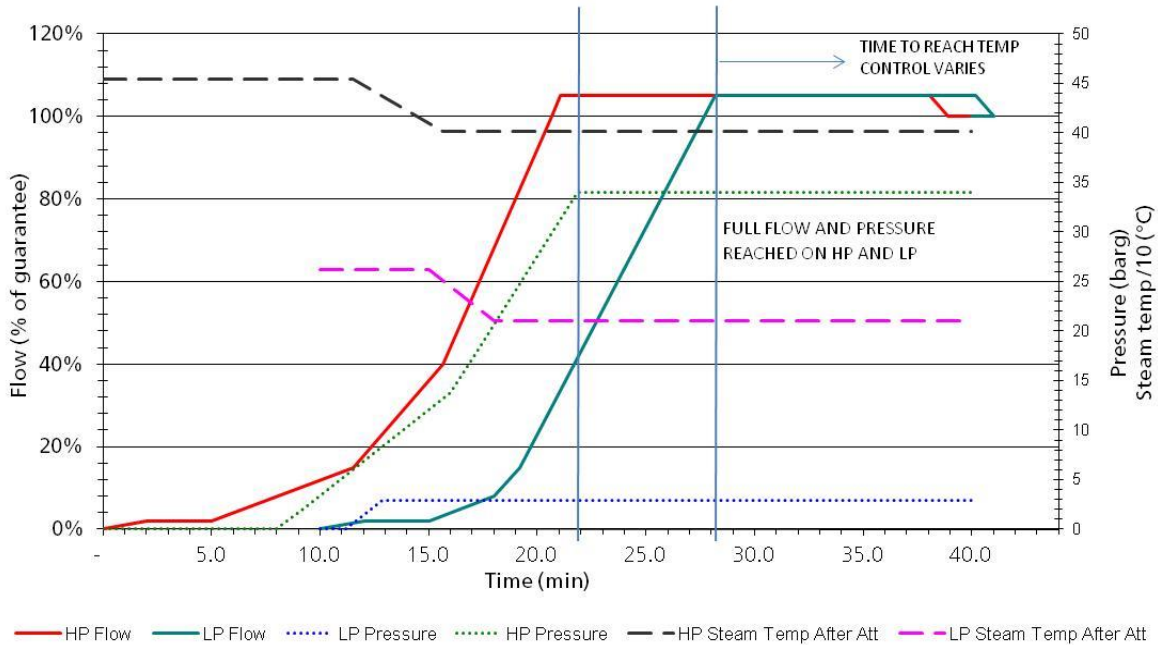

Figure 6: Typical OTSG start-up curve

6.5 Control for pH and Conductivity is Required

Since all feed water entering the OTSG pressure module is converted to steam, the feed water must be of the highest quality to ensure that no scaling occurs inside the tubing and that the purity of the steam output is suitable for the process. To ensure the quality of the feed water, the customer needs to continuously control and monitor the pH and conductivity within the specification for the OTSG.

6.6 Special Operation Considerations

It is important that steam de-superheating stations are operating properly. Failure to attain proper downstream conditions could result in equipment damage if required operating conditions are exceeded. As a point for operating consideration, excessive venting of steam from the OTSG will require high make-up rates, placing greater demand on the demineralization and chemistry control equipment. These combined effects will result in reduced plant efficiency, increased chemical consumption and accelerated exhaustion of demineralization units. The OTSG does not have the steam accumulation

ability to the same extent as a drum-type HRSG system. When the steam side of a drum plant is trip, the drums contain residue steam for a longer period than the small diameter tubes of the OTSG. Though the small diameter tubes and low water content do contribute to the boiler's response time and performance, the small diameter tubes create a large water side pressure drop which must be accounted for in the project evaluation. Essentially, the feed water pumps are sized larger than drum units and the auxiliary power consumption increases. This marginal increase in capital and operational cost can easily be offset by the elimination of the bypass stack.

7. OTSG DESCRIPTION – CONTROLS

7.1 Simple Control Structure

The OTSG has a simple control system due to simplification of the water/steam flow path and elimination of many components required for a typical HRSG. A single point of control is all that is needed. Feed water flow rate is the only control variable. Feed water is regulated at the rate necessary to produce the desired steam temperature. Since the water level can be anywhere from the first row to the outlet row, a wide range of steam flows, pressures and temperatures can be accommodated for start-up, normal operation and design optimization. The traditional drum-type HRSG has a fixed geometry superheater that cannot accommodate wide operational changes without multiple desuperheaters being employed. The OTSG allows off-design operation because in effect, it has a variable length superheater.

7.2 Flexible Operations

At the operator's preference, the OTSG can be started simultaneously with the start of the gas turbine, or, after the gas turbine is fully loaded and on-line. The OTSG is normally started hot and dry once the gas turbine has started. This is to ensure the tubes are hot. At an exhaust temperature of about 300°F (leaving the OTSG) the feedwater flow rate is ramped up as the gas turbine is loaded (similar to the fuel acceleration control for the gas turbine). When hot starts are used and water flow is below approximately 93% of design flow, the OTSG will produce superheated steam at the same temperature as the inlet gas from the gas turbine. When loaded, and the water flow is at 85% to 90% of the rated set point for gas turbine operating conditions, the feed water will go to closed loop control on superheater temperature feedback (refer to Figure 7). At steady state conditions, superheat temperature can normally be maintained at $\pm 5^{\circ}\text{F}$ of a set point or an approach temperature. Transients are accommodated with a feed-forward control strategy that sets the feed water flow to a predicted value based on turbine exhaust temperature and flow rate. The patented approach to controls and the use of microprocessors provides precise and fast transient response across a wide range of operating conditions. The OTSG has demonstrated reliable operation without difficulty, with the most demanding transients that can be required of gas turbines. This "self operating" feature is a critical benefit for

the OTSG. Combined cycle plants using OTSGs usually require 50% less operator engineers and maintenance technicians than a comparable drum-type HRSG plant. This is due to the OTSGs ability to operate itself, via the feedforward and feedback control loop. Some combined cycle plants installed in Canada and Australia operate unattended in the evening shift or remotely from distance control stations.

8. HEAT RECOVERY BOILER MAINTENANCE REQUIREMENTS

8.1 HRSGs Require Major Maintenance, OTSG's Do Not

System maintenance for a traditional HRSG is significant. The complexity of the HRSG, the number of interconnecting piping, valves, transducers, control connections, etc. requires that major work is required to keep the system operating at peak effectiveness. OTSG maintenance in comparison is minor and is typically performed during scheduled GT shutdowns. Figure 7 illustrates the simplicity of the flowsheet and instrumentation required to control and operate the unit. The amount of instrumentation is significantly less compared to a drum-type HRSG, which translates to significant maintenance savings. The OTSG, itself, does not have any moving parts, essentially it is a large heat exchanger. The ancillary equipment, such as safety valves, control valves, and attenuators have scheduled maintenance requirements as dictated by the equipment vendor, but again, the amount of equipment is reduced with an OTSG system.

8.2 Type of OTSG Maintenance

During a scheduled GT shutdown the internal tube bundle of the OTSG can be visually inspected for possible damage, leaks or other maintenance requirements. 100% of the u-bends, jumper tubes and headers are located in maintenance cavities, which have access via maintenance doors, at both ends of the unit (Figure 6). If a tube leak is present, the single circuit can be taken out of service within a few hours and the tube repair could be completed when the schedule permits. The majority of OTSGs have approximately 50 circuits of tubes in each module, therefore, if one circuit is lost in the unlikely event of a tube rupture or weld failure, the circuit would be manually blanked off and the performance would be degraded by less than 1%.

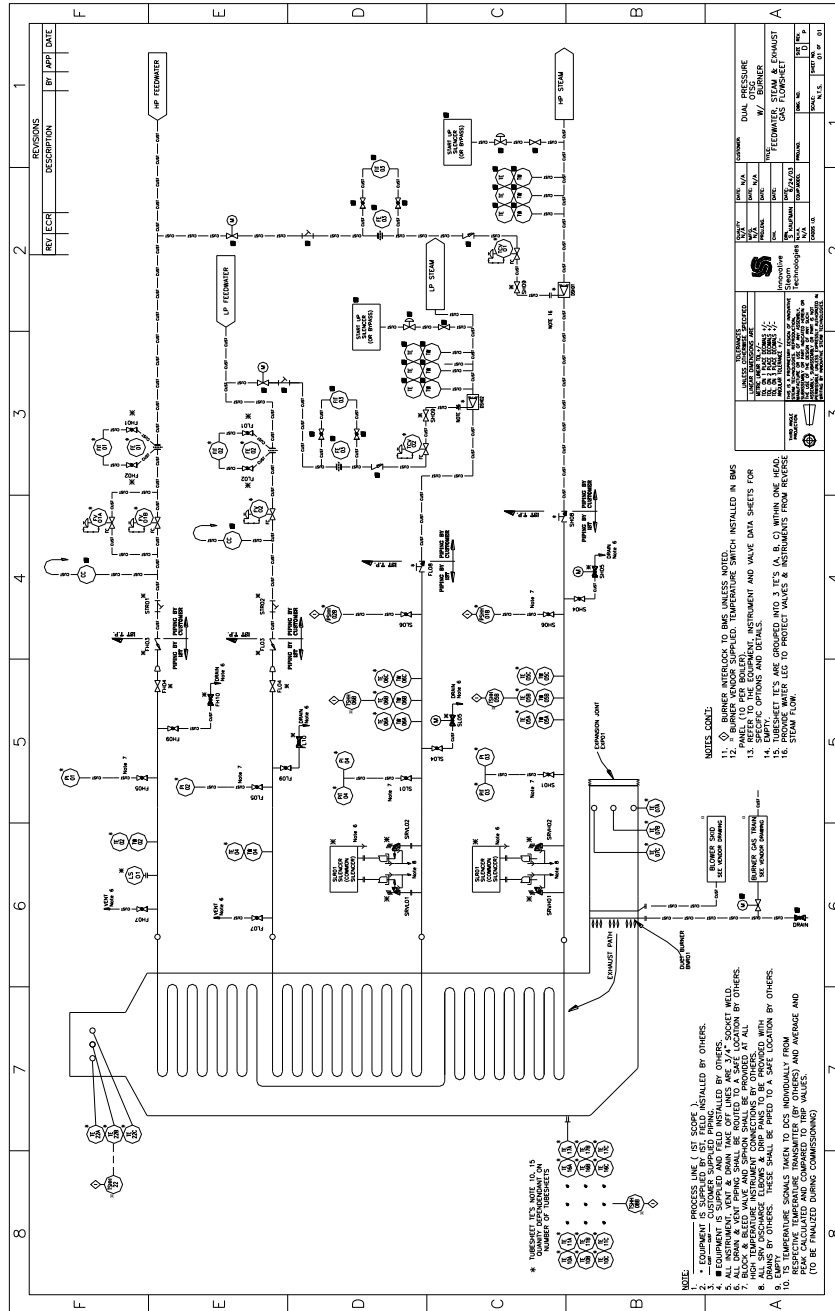

Figure 7: Typical Steam and Feedwater Flowsheet

10. ERECTION BENEFITS

10.1 Erection Cost of Most Traditional HRSG are Underestimated

The erection cost and duration of many traditional combined cycle plants are often underestimated making the initial project evaluation invalid. The installation cost is a significant portion of the overall project cost; therefore it is essential that combined cycles be evaluated on an installed basis. Traditional HRSG's cost four (4) times as much to erect as a comparable OTSG.

10.2 Modular Approach Saves Money on Installation

The modular approach minimizes time and cost associated with installation and erection of the OTSG. These savings reduce the project's gestation period making combined cycle projects increasingly more attractive to developers and financiers. Installation costs are reduced because the OTSG is designed in five modules: inlet duct, plenum, steam generator module (OTSG), hood and stack (refer to figure 3). Each of the five modules are shop fabricated and can be delivered to the point of erection by rail, road or ocean vessel. The modular design and manufacturing facilitates rapid construction and minimizes both workhours on site and crane work requirements at the erection sites. The OTSGs can be set in position within one day following the placement of the plenum. Once the plenum is set, the steam generator module, hood and stack are simply placed on top of each other and then seal welded. Additional time is required for completing the module joints and for external piping and commissioning. The installation savings of an OTSG are the single most beneficial cost savings within a project. The duration of a typical LM6000 sized OTSG takes approximately 3 weeks to complete, and is approximately 25% the cost of a drum type HRSG. Therefore, these costs must be equated in to the evaluation, and the potential cost savings would offset the cost of the polishing system and alloy material.

11. SUMMARY

Lower Installation Costs – Modular design allows for the OTSG to be completely factory designed and manufactured. These modules can be shipped to the site and installed in 25% of the time of a traditional HRSG. This reduces the amount of site work, crane work and installation.

Higher Quality Control – Modular design allows for the OTSG to be completely factory designed and manufactured. The pressure module is 100% tested using ultrasonic to ensure the best quality in the field

Faster Cycling – The OTSG has been design with the goal of minimizing the inventory of water in the steam generator. Due to this design feature, the OTSG can startup and shutdown in very short time periods. Thirty (30) minute startups are very common for the



OTSG system. This is ideal for a cycling peak load application.

Dry Run Capability – The OTSG can accommodate operating temperatures of up to 1500 F. This ability allows for use of one stack which simplifies the permit process and shortens the gestation period of the plant.

Smaller Footprint - The modular design and the compact pressure module contributes to a smaller footprint. This smaller footprint reduces the size of the overall plant and facilitates construction in very demanding locations.

Simple Controls – The controls of the OTSG are simpler due to the reduced complexity of the system. The reduction in operator requirements can lead to both cost and manpower reduction in operating of the plant.

Simple Operation – The operation of the OTSG is simpler due to the reduced complexity of the system. The reduction of both the steam drum and the blowdown system results in less thermal mass and less operator action.